

Chapter C7

BDRP rotary shaft seals



Revision 7 January 30, 2025

Individual chapters of the Kalsi Seals Handbook™ are periodically updated. To determine if a newer revision of this chapter exists, please visit <https://www.kalsi.com/seal-handbook/>.

NOTICE: The information in this chapter is provided under the terms and conditions of the Offer of Sale, Disclaimer, and other notices provided in the front matter of this seal handbook.

1. Introduction to BDRP rotary shaft seals

BDRP™ Seals (Figure 1) are direct compression-type rotary seals developed specifically to be hydrodynamically lubricated during rotation regardless of which side pressure acts from. This feature makes them an excellent candidate for use as a hydraulic swivel seal or as a rotary control device seal (RCD seal) with a simple gravity fed lubricant reservoir.

The acronym “*BDRP*” stands for Bi-Directional Rotation and Pressure. The patented BDRP Seal™ is designed to accommodate either direction of rotation and either direction of pressure. With the pressure of a non-abrasive fluid acting from the side opposite the waves, BDRP Seals™ have been tested with 1,000 psi (6.89 MPa) at 466 sfpm (2.37 m/s) and with 1,500 psi (10.34 MPa) at 275 sfpm (1.39 m/s). With the pressure of a seal lubricant acting from the wave side of the seal, the BDRP Seal has the same extreme pressure capacity as an Extra Wide Plastic Lined Seal™.



Figure 1
BDRP rotary shaft seals

The BDRP rotary seal is a patented composite direct compression seal for separating a lubricant from a non-abrasive fluid, with differential pressure acting in either direction. When used with a barrier seal, pressurized abrasive fluids can be retained. Because of the ability to withstand either direction of differential pressure, the lubricant can be supplied from an unpressurized reservoir. The BDRP Seal also accommodates either direction of rotation.

2. Description of BDRP rotary shaft seals

BDRP Seals have composite construction consisting of an elastomer seal body lined with a layer of plastic that forms the dynamic sealing surface. The plastic layer is loaded against the shaft by radial compression of the elastomer portion of the seal. The plastic layer is bonded to the elastomer portion. This prevents the damaging component slippage that is common to rotary cap-type hydraulic swivel seals.¹

¹ Cap seals are also known as glide rings.

The plastic layer extends from one end of the seal to the other, and resists differential pressure-induced deformation. One side of the plastic layer incorporates hydrodynamic waves that face a lubricant. These waves are specially designed to resist differential pressure-related deformation, so they remain functional when the pressure of the lubricant is much less than the pressure of the non-abrasive fluid.

During rotation, the waves hydrodynamically wedge a film of lubricant between the shaft and the plastic layer of the seal. This hydrodynamic interfacial lubrication reduces friction, wear, and friction-generated temperature, and enables the excellent high-pressure performance of the BDRP Seal.

3. Availability of BDRP Seals

A table of available seal sizes and gland dimensions is provided on our website. Other seal sizes can be furnished, subject to a one-time tooling charge to help to defray associated engineering, machining and set-up expenses.

4. Removable groove walls are required for some BDRP Seal sizes

The plastic liner of a BDRP Seal is made from our robust -35 plastic seal material. Because of the stiffness of the -35 material, some sizes of BDRP Seals require a removable groove wall to prevent liner damage during installation into the housing groove. The larger the inside diameter (ID_{seal}) of a BDRP Seal is relative to its radial cross-sectional depth (D) the more likely it is to install in a one-piece groove without damage. In our testing, a BDRP Seal with an ID_{seal}/D of 25.177 installed easily into a one-piece seal groove and did not require a removable groove wall.

A seal installation tool may allow the BDRP to be installed in a fixed groove without damage. For more information on this, please [contact](#) our Seals Engineering team.

5. Using a BDRP Seal as a hydraulic swivel seal

When using a BDRP Seal as a hydraulic swivel seal, two seals are required to define a single hydraulic circuit, three seals are required to define two hydraulic circuits, four seals are used to define three hydraulic circuits, and so on. In other words, the same as when cap seals are used. (If pressures higher than 1,000 psi (6.89 MPa) are anticipated, two Kalsi Seals are required to define every hydraulic circuit, in order that the fluid pressure only acts from the wavy side of the dynamic sealing lip.)

When installing the BDRP Seals, the waves of each seal should face a hydraulic fluid circuit. The swivel should be configured so that the waves of each seal are exposed to

For available seal sizes, visit kalsiseals.com.

hydraulic fluid during rotation. When necessary, use check valves or a gravity-based fluid trap to accomplish this (Figure 2).

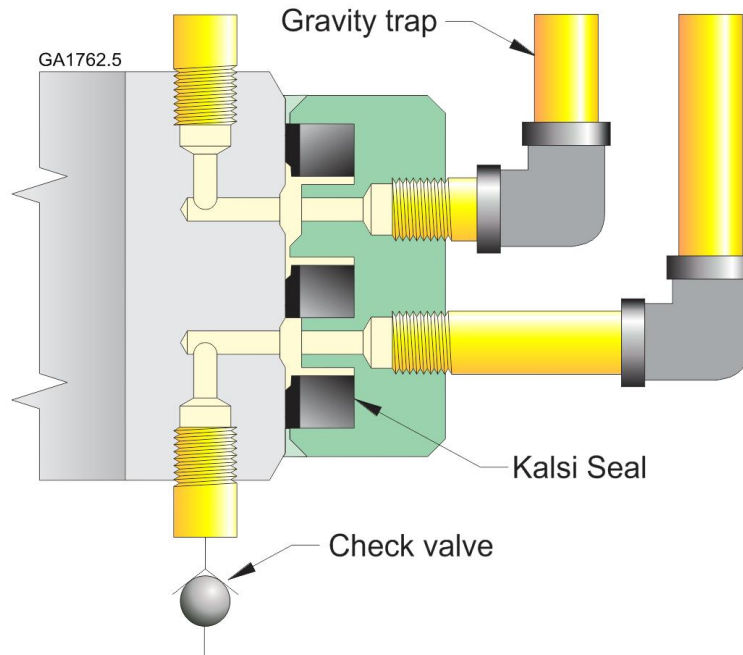

Figure 2

Keeping the waves of a hydraulic swivel seal exposed to lubricant

When using the BDRP as a hydraulic swivel seal, take steps to ensure that the wavy side of each dynamic lip is exposed to hydraulic fluid. As shown in this schematic of a hydraulic swivel, a gravity trap or a check valve can be used to achieve this objective.

10.50" Hydraulic swivel seal-related tests

Two tests of 10.50" (266.7mm) diameter BDRP seals (PN 717-11-318) have been run to simulate hydraulic swivel conditions. The test setup is shown in Figure 3. The mandrel was rotating at 120 RPM (329 sfpm or 1.67 m/s) and an ISO 68 VG lubricant was pressurized to 1,000 psi (6.89 MPa) between a pair of BDRP seals. The upper BDRP seal had an ISO 68 VG lubricant above it pressurized at 5 to 7 psi (0.03 to 0.05 MPa). This seal was installed with the waves toward the low-pressure hydraulic oil while the lower seal was installed with the waves toward the high-pressure hydraulic oil.

The first test was run for 115 hours and the seals were in very good condition at the end of the test. To confirm performance a second test was run. The second test was run for 265 hours and the test seals were also in very good condition at the conclusion of the test, as can be seen in Figure 4.

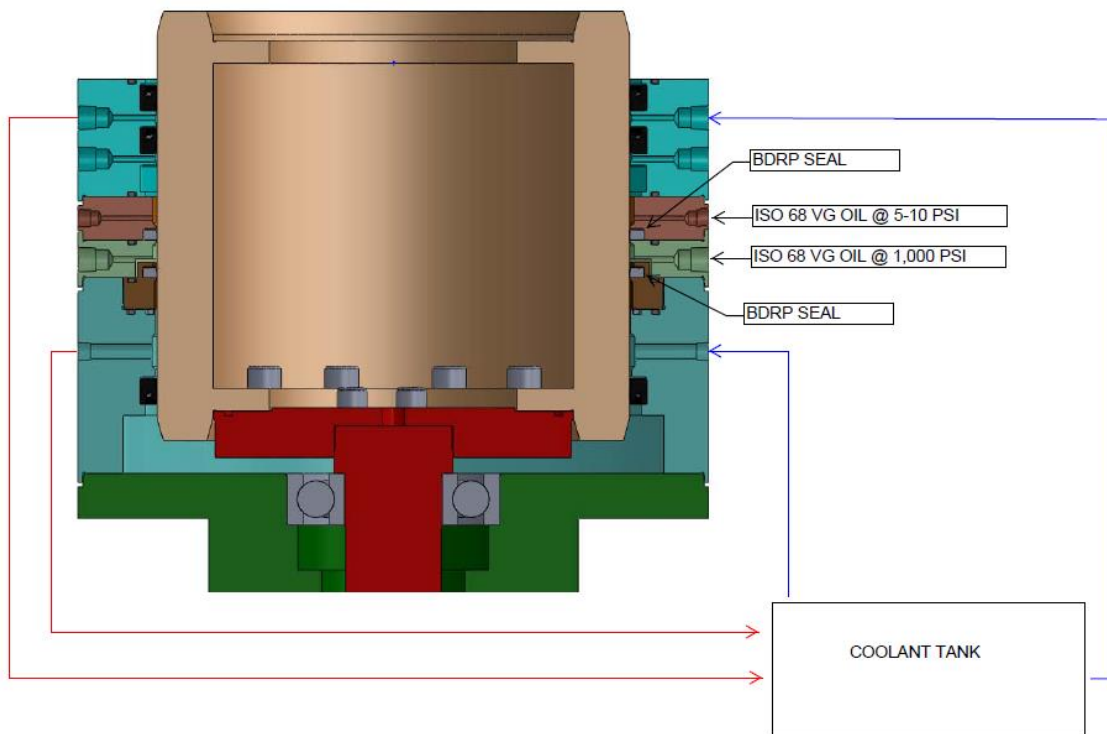

Figure 3

Kalsi Engineering high-pressure hydraulic swivel seals test setup

This schematic shows the test setup used to test a pair of BDRP seals. Both seals are installed with the wave up. This subjects the upper BDRP seal to pressure acting from the least pressure capable side and the lower BDRP to the most pressure capable side.



Figure 4

Seals from a 1,000 psi test simulating hydraulic swivel sealing conditions

These photos show the condition of BDRP seals after running for 265 hours on a 10.50" mandrel rotating at 120 RPM. The seals were retaining an ISO 68 VG hydraulic oil at 1,000 psi. The upper seal was pressurized from the non-wavy lower side which is the seal's least pressure capable side.

4.50" Hydraulic swivel seal-related tests

For available seal sizes, visit kalsiseals.com.

Two tests of 4.5" (114.3mm) diameter BDRP Seals (PN 717-2-318) have been run simulating hydraulic swivel conditions. For these tests, a 68 viscosity grade lubricant was pressurized to 1,000 psi (6.89 MPa) on one side of the BDRP Seal and the lubricant vented to atmosphere on the other side. The shaft rotated at 220 RPM (259 sfpm or 1.32 m/s). The tests were run for 216 hours and 210 hours. In both cases, the posttest seal condition was excellent. Figure 5 shows the posttest condition of the BDRP Seal after 216 hours.



Figure 5

Seals from a 4.50" 1,000 psi test simulating hydraulic swivel sealing conditions

This is a 4.50" rotary seals from the 1,000 psi, 259 sfpm test with a 68 VG lubricant. This seal received the pressure on the non-wavy lower side. After 216 hours of operation, this high-pressure shaft seal is still in excellent condition.

6. Using a BDRP Seal as an RCD seal

When using a BDRP Seal as an RCD seal, an outboard barrier seal is required, with the region between the two seals being filled with a barrier lubricant that is balanced to the pressure of the well (Figure 6). The barrier seal excludes the abrasive drilling fluid but is exposed to zero differential pressure, and the BDRP Seal retains the pressure of the barrier lubricant, but is isolated from the abrasive drilling fluid.

The seal lubricant can be gravity fed from a simple unpressurized lubricator.² In an RCD, the seal could be mounted below the bearings and utilize the bearing lubricant to lubricate the interface between the BDRP Seal and the rotating mandrel. No complicated lubricant overpressure system is required. Our lubricant return valve (U.S. Patent 10,435,981) is recommended to return the hydrodynamic pumping related leakage of the BDRP Seal to the bearing lubricant chamber.

² If a gravity fed lubricator is mounted remotely, any connecting hoses or piping must be free of restrictions that could prevent gravity-induced flow of the viscous lubricant. During seal testing, we experienced problems when a small but open valve added enough restriction to a lubricant supply line to prevent gravity-induced lubricant flow.

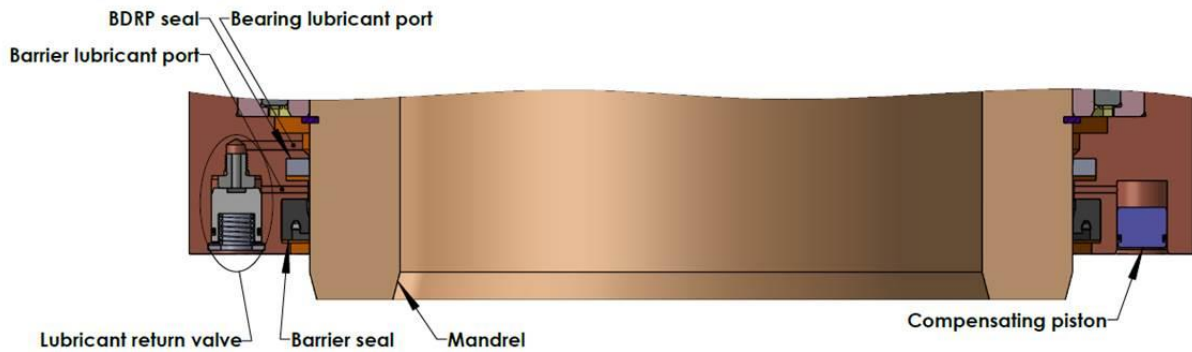

Figure 6
Using the BDRP as an RCD seal

When using the BDRP as an RCD seal, use an outboard barrier seal to separate the drilling fluid from a barrier lubricant. Balance the pressure of the barrier lubricant between the seals to the pressure of the drilling fluid. In this illustration, small local balancing pistons perform the pressure balancing function, and a Kalsi-designed lubricant return valve (U.S. Patent 10,435,981) returns the hydrodynamic pumping related leakage of the BDRP Seal to the bearing lubricant chamber.

1,000 psi 10.5" RCD seal tests

With RCD sealing in mind, a 10.49" (266.45mm) diameter PN 717-1-318 BDRP Seal was tested at 170 rpm (466 sfpm) and 1,000 psi (6.89 MPa) for 179 hours. The test fixture, which is shown by Figure 7, was custom built to test seals for rotary control devices (RCDs).

The upper seal was a PN 717-1-318 BDRP Seal, and the lower seal was a PN 682-12-318 Plastic Lined Kalsi Seal™. Both seals were installed in non-floating seal carriers that define a radial extrusion gap clearance of 0.020" (0.51mm). The dynamic runout was 0.007" (0.18mm) FIM at the upper rotary seal, and 0.003" (0.08mm) FIM at the lower rotary seal.

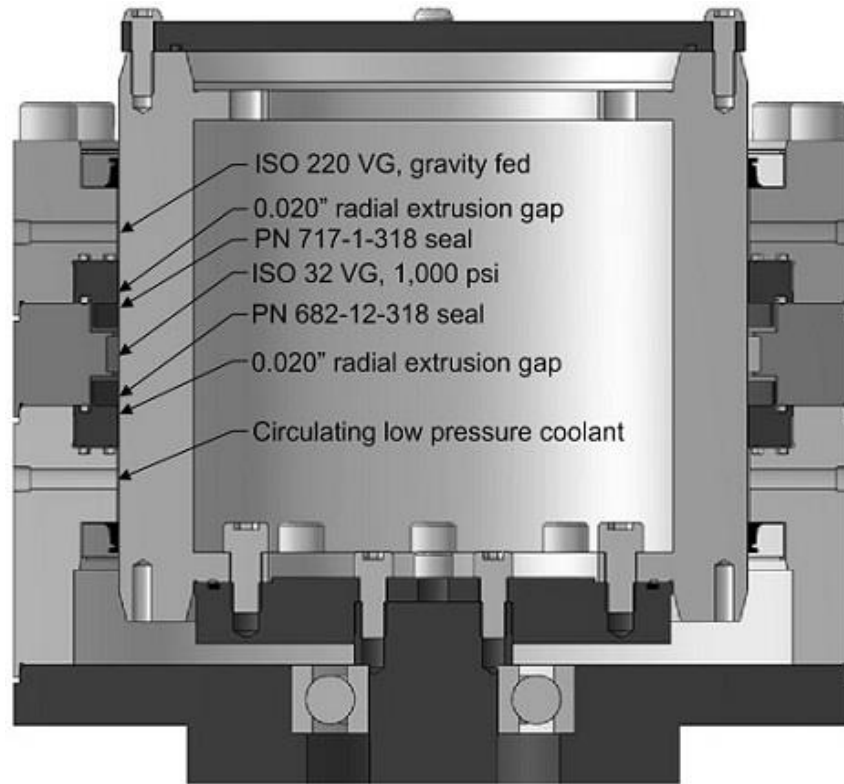

Figure 7

Kalsi Engineering has a dedicated fixture for testing high pressure RCD seals

To better understand the challenges faced by our customers, Kalsi Engineering designed and built this fixture to test the pressure-retaining seals of an RCD. The flexible design of the fixture allows different types of rotary seals and seal carriers to be tested.

The hydrodynamic waveforms of both seals were oriented upward. The lubricant for the BDRP Seal was an ISO 220 viscosity grade lubricant that was unpressurized and delivered to the seal by gravity. The 1,000 psi (6.89 MPa) test pressure was applied to the underside of the BDRP Seal via an ISO 32 viscosity grade lubricant simulating a pressurized barrier lubricant. This lubricant also served to lubricate the lower rotary seal, which was used to retain the 1,000 psi (6.89 MPa) test pressure.

In an actual RCD, a portion of the lower end of the mandrel is exposed to the flowing drilling fluid, which has a cooling effect on the mandrel. In the test fixture, a 111 to 119°F (43.9 to 48.3°C) coolant was circulated under the lower seal at approximately 2 gpm to create a thermal environment at the upper seal that simulates an RCD that has no circulation of the bearing lubricant. No other circulation was provided during the test. The temperature immediately above the upper rotary seal ranged from about 136 to 150°F (57.8 to 65.6°C), and the temperature between the seals ranged from about 152 to 170°F (66.7 to 76.7°C).

For available seal sizes, visit kalsiseals.com.

The test was stopped at 179 hours to make the fixture available for other pending tests. The BDRP Seal was still in good condition, with very little detectible wear, showing that the seal can withstand a pressure differential of 1,000 psi (6.89 MPa) at 466 fpm (2.37 m/s) with only moderate cooling (Figure 8).

The lower seal was in excellent condition, with no detectible wear, easily withstanding the 1,000 psi (6.89 MPa) differential pressure at 466 sfpm (2.37 m/s) while experiencing excellent interfacial lubrication with a low viscosity (ISO 32 viscosity grade) lubricant (Figure 8).

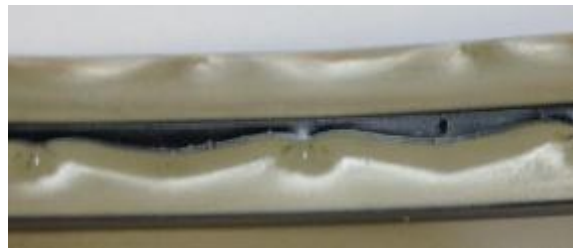

Figure 8

Seals from a 1,000 psi test simulating RCD sealing conditions

These are the 10.49" rotary seals from the 1,000 psi, 466 fpm test. The upper seal (the BDRP seal) received the pressure on the non-wavy lower side, and the lower seal received the pressure on its wavy upper side. After 179 hours of operation, both of these high-pressure shaft seals are still in great condition.

1,500 psi 10.5" RCD seal tests

A 10.49" (266.45mm) diameter PN 717-1-318 BDRP Seal was tested at 100 rpm (275 sfpm) and 1,500 psi (10.34 MPa) using the RCD seal test fixture shown in Figure 7. Note that the pressure between the 717-7-318 seal and the 682-12-318 seal was set to 1,500 psi. The test ran for 233 hours. The test seal was in excellent condition at the conclusion of the test as seen in Figure 9.

The 717-1-318 seal was installed such that the hydrodynamic waves (wavy side) faced toward the ISO 320 viscosity grade lubricant at 10 psi, while the environment side (non-wavy side) of the seal faced the ISO 320 viscosity grade lubricant at 1,500 psi.

Coolant was circulated below the 682-12-318 seal. The coolant temperature at the inlet was 90°F. No other coolant circulation was provided during the test, and the test temperature between the seals remained steady between 112°F and 121°F.

For available seal sizes, visit kalsiseals.com.

During the test, the 717-1-318 BDRP seal pumped lubricant from the low-pressure side (10 psi) into the high-pressure side (1,500 psi) at a rate of 18 ml/hr.



Figure 9

BDRP test seal from a 1,500 psi test simulating RCD conditions

This is the 10.49" rotary seal from the 1,500 psi, 100 RPM test. The seal was exposed to 1,500 psi of pressure on the non-wavy lower side, and 10 psi of lubricant pressure on the wavy top side. After 233 hours of operation, the 717-1-318 BDRP test seal was in excellent condition.